

Ethernet SAN or Fibre Channel SAN

Server virtualization and storage consolidation are two emerging trends increasing demand for shared storage. When it comes to choosing a storage area network (SAN) infrastructure, questions about performance, ease-of-use and cost are sure to come up. This technical brief reviews key differences to consider between Ethernet SAN and Fibre Channel SAN infrastructure when choosing a storage solution for your next virtual server or cloud storage project.

Networking Technology

This may be obvious, but it's worth mentioning: Ethernet SANs run on standard Ethernet - the same Ethernet technology IT departments are already familiar with. Fibre Channel SAN uses a specialized Fibre Channel network.

Today, Fibre Channel SANs typically operate with port speeds from 2Gbps to 8Gbps. There is talk of moving towards 16Gbps, but beyond this is a big industry question mark. Ethernet SAN supports 10Gbps port speeds today, using standard Ethernet, with 40Gbps and 100Gbps on the horizon (Figure 1).

Fibre Channel SAN is implemented with arbitrated loops or an expensive switched fabric. The Fibre Channel protocol consists of several complex software layers (see Figure 2). These layers force users through mandatory SAN configuration procedures for each network path on all storage LUNs. Ethernet SAN is a connectionless protocol that connects servers and storage directly across layer 2 Ethernet. It does not require TCP/IP or user configured multi-path IO (MPIO) software. The use of layer 2 Ethernet represents a simpler approach for SAN. With Ethernet SAN packets are automatically sent over every available network path between the server and storage (without MPIO configuration). Ethernet SAN is robust, every packet is checked for bit errors and all packets are acknowledged. Ethernet SANs low latency allows dropped packets to be retransmitted immediately insuring high throughput and reliability.

This is an extremely fast and simple method for sharing disk drives through a low latency network. Since Ethernet SAN doesn't need TCP/IP, it has less overhead, lower latency and automatically utilizes all network paths. Coraid's EtherDrive storage products take full advantage of Ethernet SANs simplicity to deliver storage that will outperform Fibre Channel at fraction of the cost.

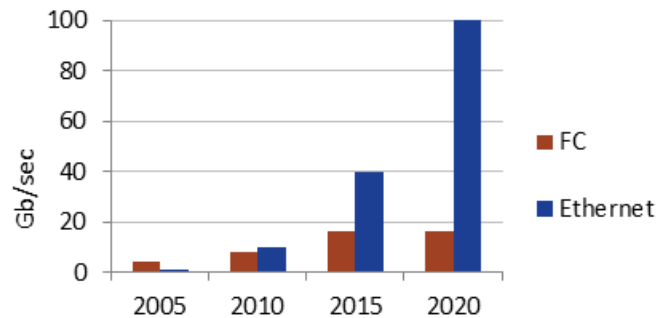

Figure 1

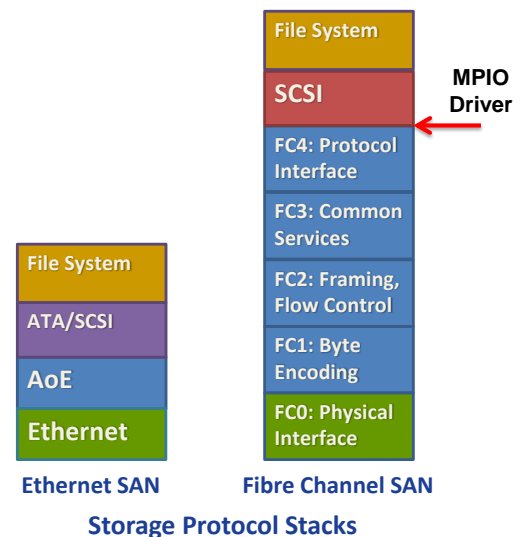

Figure 2

Management

Ethernet SANs are less complex than Fibre Channel, thus easier to install, configure, and manage. Ethernet SAN storage integrates with a server's operating system (OS) using a simple driver that enables the OS to mount Ethernet SAN storage arrays as if they were local drives. The ability to take advantage of networked storage as if it were locally attached disk allows common storage functions to be performed quickly and easily, reducing wait times for storage deployments. Based on the number of steps in Table 1, a Fibre Channel SAN can take hours to set up, compared to the five steps and few minutes for an Ethernet SAN.

Table 1:

Steps	Fibre Channel	Ethernet SAN
1	Plug in physical HBA	Plug in Physical HBA
2	Load HBA specific firmware	Load HBA specific firmware
3	Install MIPO driver	Create LUN on storage array (one command)
4	Configure storage port connections	On-line LUNs are automatically discovered
5	Capture WWN (will need this later)	Not required
6	Perform LUN discovery	Not required
7	Log into LUN (requires storage access)	Not required
8	Zone HBA to storage port (MPIO requires zone for each path)	Optional - using standard Ethernet VLANs
9	Configure NPIV (if Vmotion required)	Not required
10	Configure storage	Completed in step 3 above
11	Mask Initiator (requires WWN)	Optional - using standard Ethernet MAC filtering
12	Go to the HBA and perform a LUN discovery	Not required
13	Mount disk	Mount disk
	13 steps = Hours	5 steps = Minutes

Performance

Since Fibre Channel has built its reputation on performance, it is surprising to many that Ethernet SAN can achieve even higher performance than traditional architectures. But in fact, Ethernet SANs are capable of near line-rate performance using commodity 1Gbps and 10Gbps Ethernet, delivering throughput that is up to 30% faster than Fibre Channel. ESG Labs tested the Coraid SRX3200 Ethernet SAN storage array with 24 drives and showed it can deliver up to 1200 MB/sec throughput per shelf (figure 3 below). Put into perspective, a single shelf was able to drive enough bandwidth to saturate a 10Gbps interface.

Ethernet SANs I/O performance is impressive too. Figure 4 shows in a Microsoft Exchange environment as more drive spindles are added the performance of Ethernet SAN scales linearly. In this example a single Ethernet SAN disk array was able to support enough transactional I/O to support 9,000 users with 24 SAS disk drives.

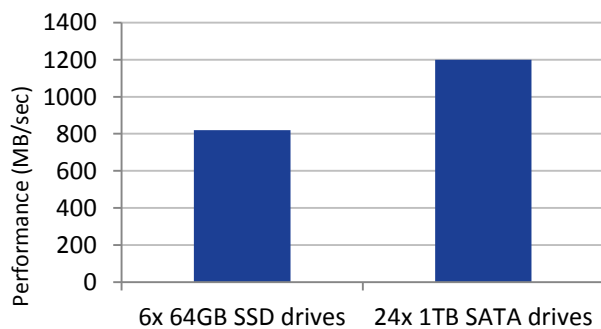

Figure 3

As Figure 3 shows, streaming media performance was excellent, delivering 826 MB/sec from just 6 SSD drives and more than 1,200 MB/sec from 24 SATA drives.

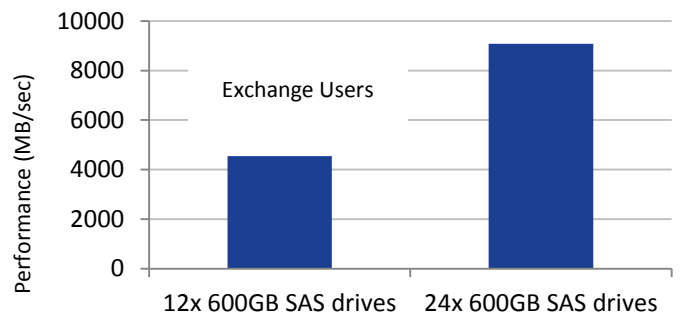

Figure 4

As can be seen in Figure 4, a single SRX3500 LUN was able to support enough transactional IO to support more than 4,500 Exchange users using just 12 SAS drives and scaled linearly to just over 9,000 users with 24 SAS drives.

Cost

Ethernet SAN is generally one-fifth the cost of Fibre Channel SAN infrastructure. The reasons for this include the cost of components, networking technologies and software complexities used in each type of SAN technology. Fibre Channel is a specialized network requiring expensive switches, array controllers, host bus adapters, and complicated software, such as multi-path drivers.

Ethernet SAN uses commodity Ethernet switches, does not require complicated multi-path software and leverages industry standard networking components and disk drives. ESG Lab compared the cost of acquisition for a petabyte of storage and network connectivity for both Fibre Channel and Ethernet SAN in their August 2010 Validation Report: *Coraid EtherDrive SAN* (see Table 2).

Table 2: CAPEX cost details based on 1 PB of Networked Storage

	Ethernet SAN	Fibre Channel SAN
Hardware	\$1,272,177	\$5,549,594
Connectivity	\$77,320	\$1,257,954
Total	\$1,349,437	\$6,807,549

Each storage technology was configured to support the same class and quantities of storage. SAN connectivity was calculated to support 200 physical servers with redundant connections. The cost of storage and SAN connectivity hardware was obtained from a combination of publically available sources, including reseller websites, GSA pricing schedules, and online pricing available directly from vendors.

Ethernet SAN has the lowest cost of acquisition, by a wide margin.

Conclusion

Analyst firms report that storage costs consume 25% to 40% or more of IT budgets. Companies are under constant pressure to find ways to reduce storage costs. Investing in new technology that helps reduce capital and operational costs in the storage environment makes sense.

While the performance of Ethernet SAN is impressive, what is most impressive is the simplicity and lower cost of Ethernet SAN, making management of petabytes a reasonable task. If your organization is struggling to keep up with exponential data growth while at the same time controlling cost and providing ever higher levels of performance and availability, consider Ethernet SAN as the infrastructure for your next shared storage SAN deployment.

For additional information on Ethernet SAN, check out our more in depth Ethernet SAN resource page.
<http://www.coraid.com/resources>